

# HIGH EFFICIENT RIGID MOUNTED INDUSTRIAL WASHER EXTRACTORS

**RX  
RANGE**

**RX 80**

7,5KG  
16LB

**RX 105**

10,5KG  
23LB

**RX 135**

13,5KG  
30LB



## FEATURES

- Rigid mounted, normal spin, up to 200G factor
- Stainless steel drum and tub
- Patented soap hopper
- Large drain valve (Ø 76 mm)
- Easy access to all vital parts from the front
- Large door opening for easy loading & unloading

## OPTIONS

- XControl - Fully programmable
- Anthracite grey painted panels
- Stainless steel front and side panels
- USB plug (on the back panel)
- Prep for coin and Central Pay
- Liquid soap connection
- Liquid soap pumps
- Steam heating version
- Drain pump (RX80)
- ECO version: Lower kW rating on request



ERGONOMIC  
CONSTRUCTION



LARGE DOOR  
OPENING



LOW WATER  
AND ENERGY  
CONSUMPTION

TYPE		RX80	RX105	RX135
<b>INNERDRUM</b>				
Capacity 1:09	kg (lb)	8(18)	12(26)	15(33)
Capacity 1:10	kg (lb)	7,5(16)	10,5(23)	13,5(30)
Volume	litres	75	105	135
Diameter	mm	530	620	620
<b>DRUM SPEED</b>				
Wash	rpm	50	46	46
Extraction	rpm	820	760	760
<b>G-FACTOR</b>				
		200	200	200
<b>HEATING</b>				
<b>ELECTRICITY</b>				
very low-low-std-higher-special 1 -2-3	kW	3-4,6-6-9--7--	3---9-12-6-7--	3---12-13,8-6-7-9
Steam	bar	1 - 8	1 - 8	1 - 8
Hot water	°C	90	90	90
Sound pressure level	dB (A)	< 65	< 65	< 65
Water valves connection	BSP	3/4"	3/4"	3/4"
Water pressure	kPa	100-800	100-800	100-800
Rec. water pressure	kPa	300-500	300-500	300-500
Water inlet	l/min	20	20	20
Drain valve	outer Ø mm	76	76	76
Flow amount with drain valve	l/min	210	210	210
Steam valve connection	BSP	1/2"	1/2"	1/2"
Steam pressure	kPa	100-800	100-800	100-800
<b>DIMENSIONS</b>				
Size H×W×D	mm	1115×660×785	1225×750×785	1225×750×900
Net weight	kg	135	170	190
<b>TRANSPORT DATA</b>				
Packed H×W×D	mm	1245×710×835	1355×800×835	1355×800×950
Gross weight	kg	145	185	200

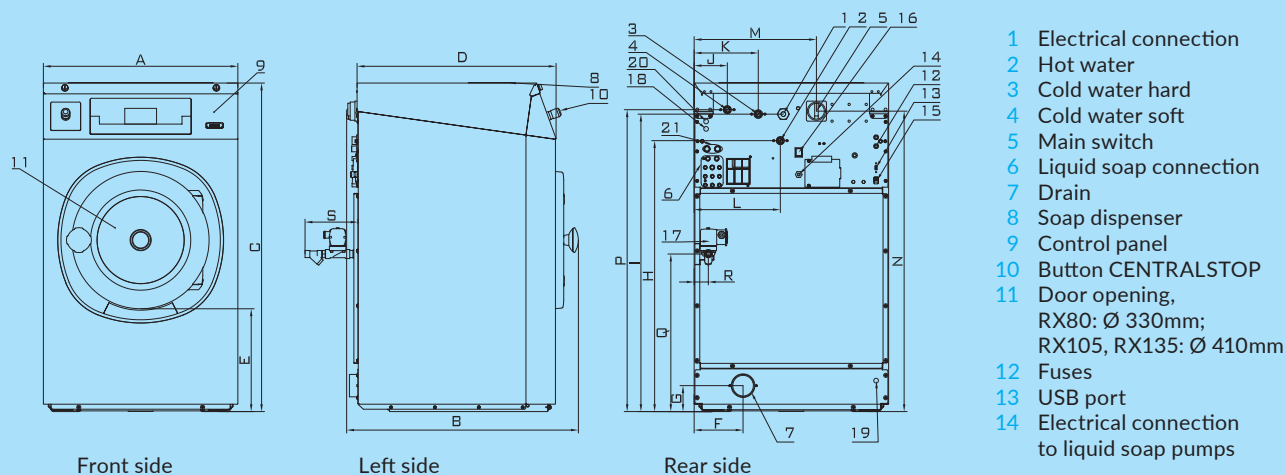

## DIMENSIONS

	A	B	C	D	E	F	G	H	I	J	K	L	M	N	P	Q	R	S
RX80	660	785	1115	676	349	166	88	920	1010	113	218	293	415	1020	1025	535	48	180
RX105	750	785	1225	676	342	225	98	1030	1120	113	218	338	505	1130	1135	480	42	192
RX135	750	900	1225	788	342	225	98	1030	1120	113	218	338	505	1130	1135	480	42	192
	width	depth	height															

		RX80
Water consumption	l/kg	6,9
Electricity consumption	kWh/kg	0,17



\* Program No 11

The Primus preserves the right to change the machines and the specification in this leaflet at any time, without prior notice. Details and photographs are only for information and never binding.  
[www.primuslaundry.com](http://www.primuslaundry.com)

Primus by Alliance Laundry Systems